

M9.21/M9.21S	P/N 36961-103	REV. L
DRAWN BY: C. BELGARDE	DATE: 9/5/97	SHEET 1 OF 5

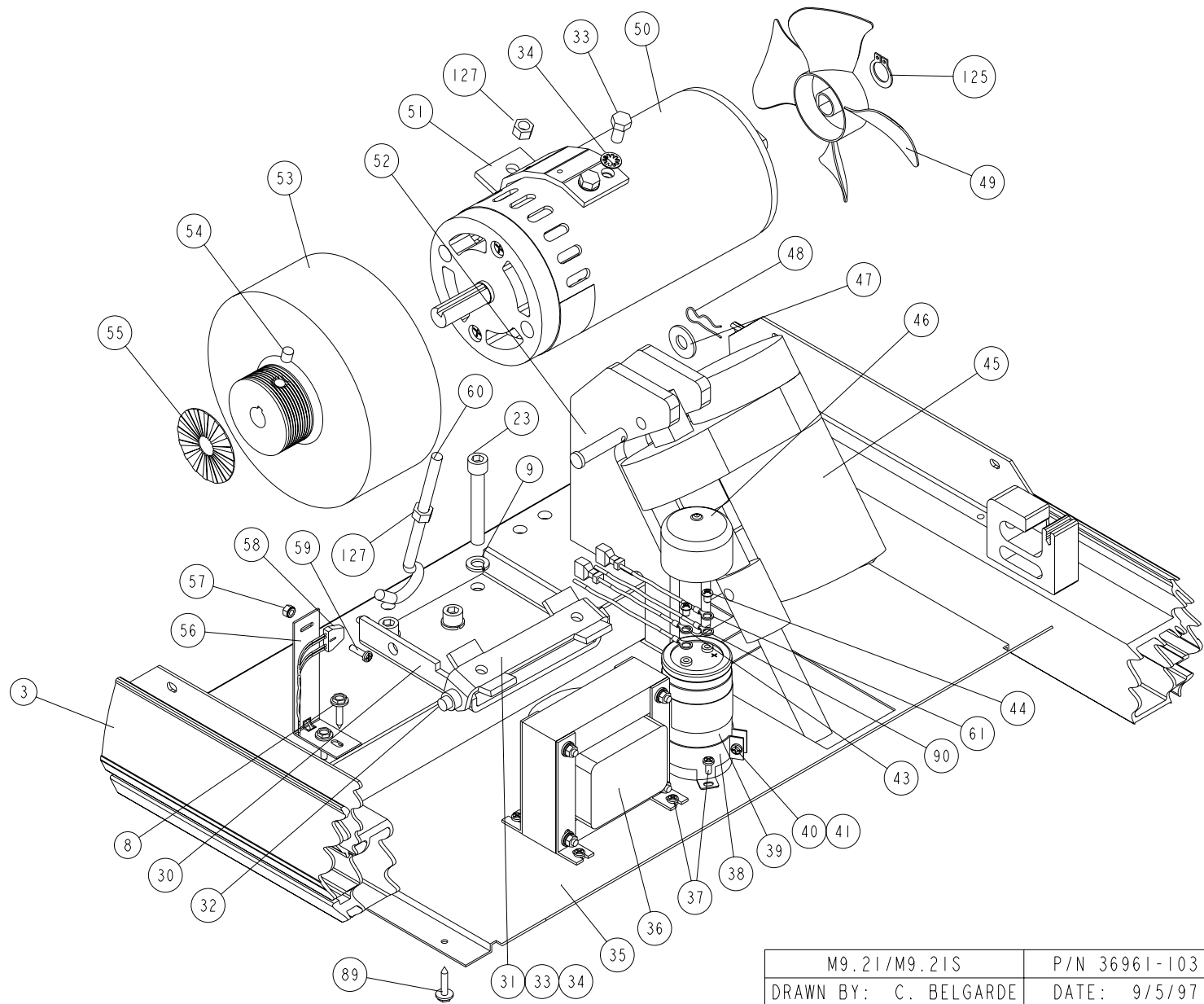

M9.21/M9.21S	P/N 36961-103	REV. L
DRAWN BY: C. BELGARDE	DATE: 9/5/97	SHEET 2 OF 5

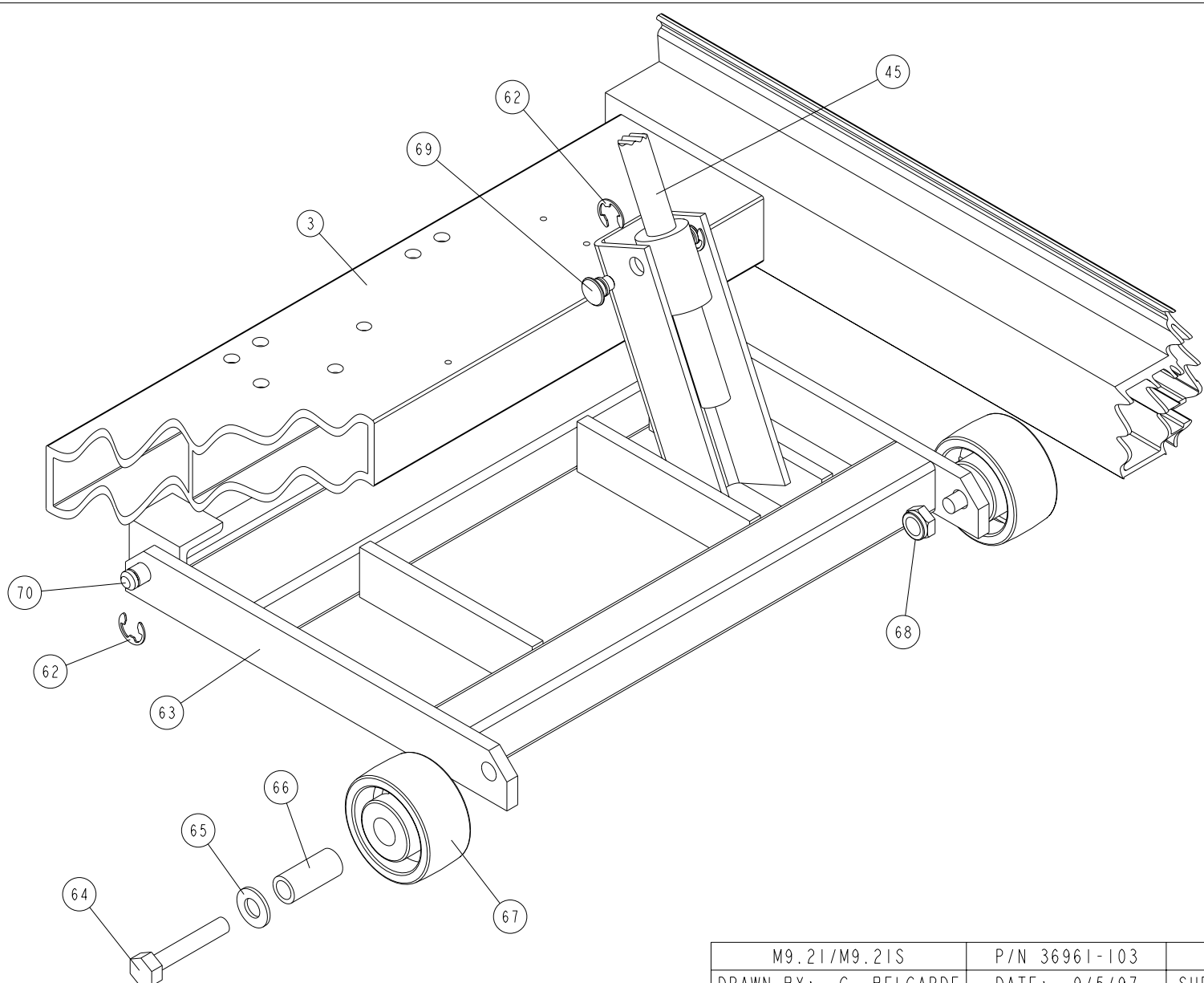

M9.21/M9.21S	P/N 36961-103	REV. L
DRAWN BY: C. BELGARDE	DATE: 9/5/97	SHEET 3 OF 5

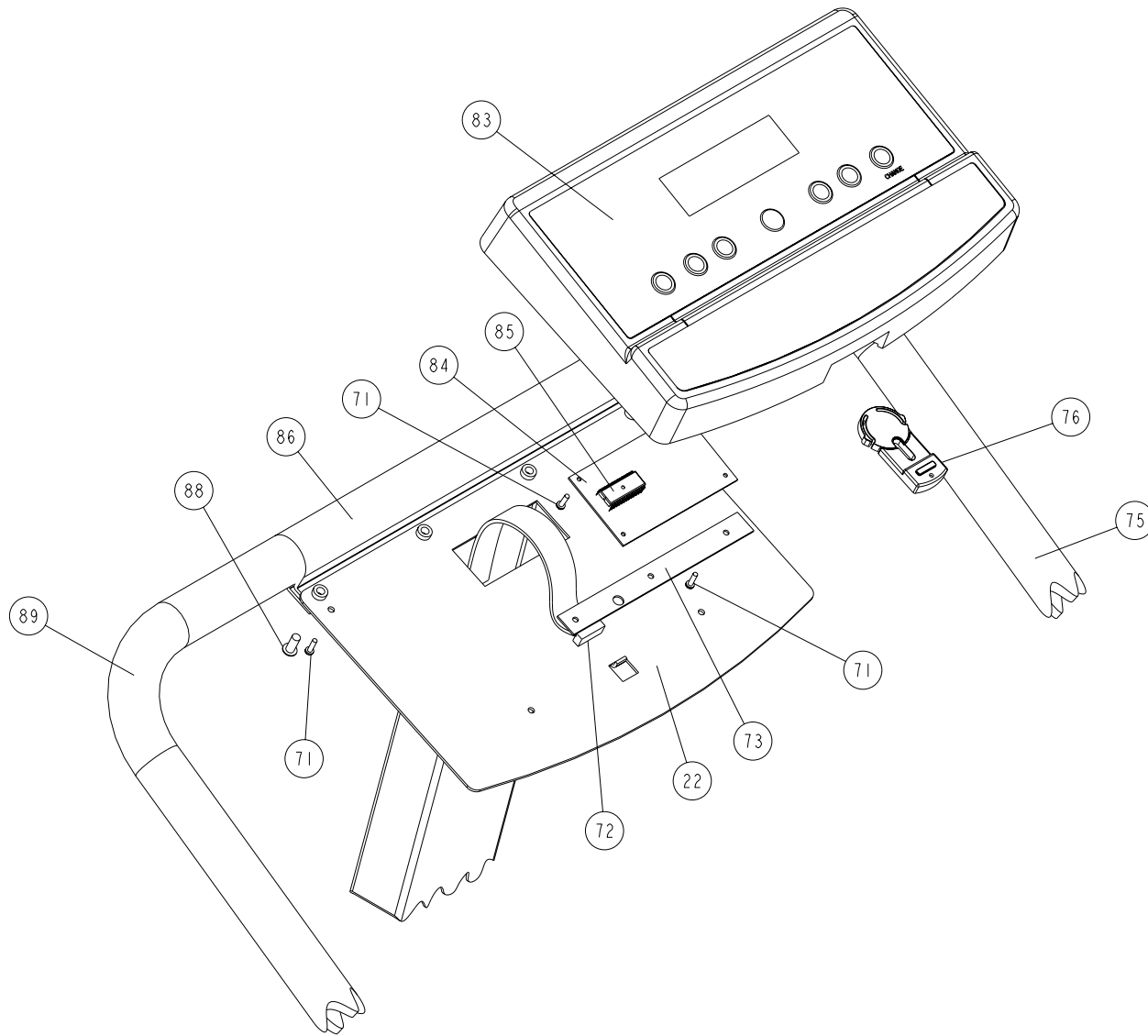

M9.21/M9.21S	P/N 36961-103	REV. L
DRAWN BY: C. BELGARDE	DATE: 9/5/97	SHEET 4 OF 5

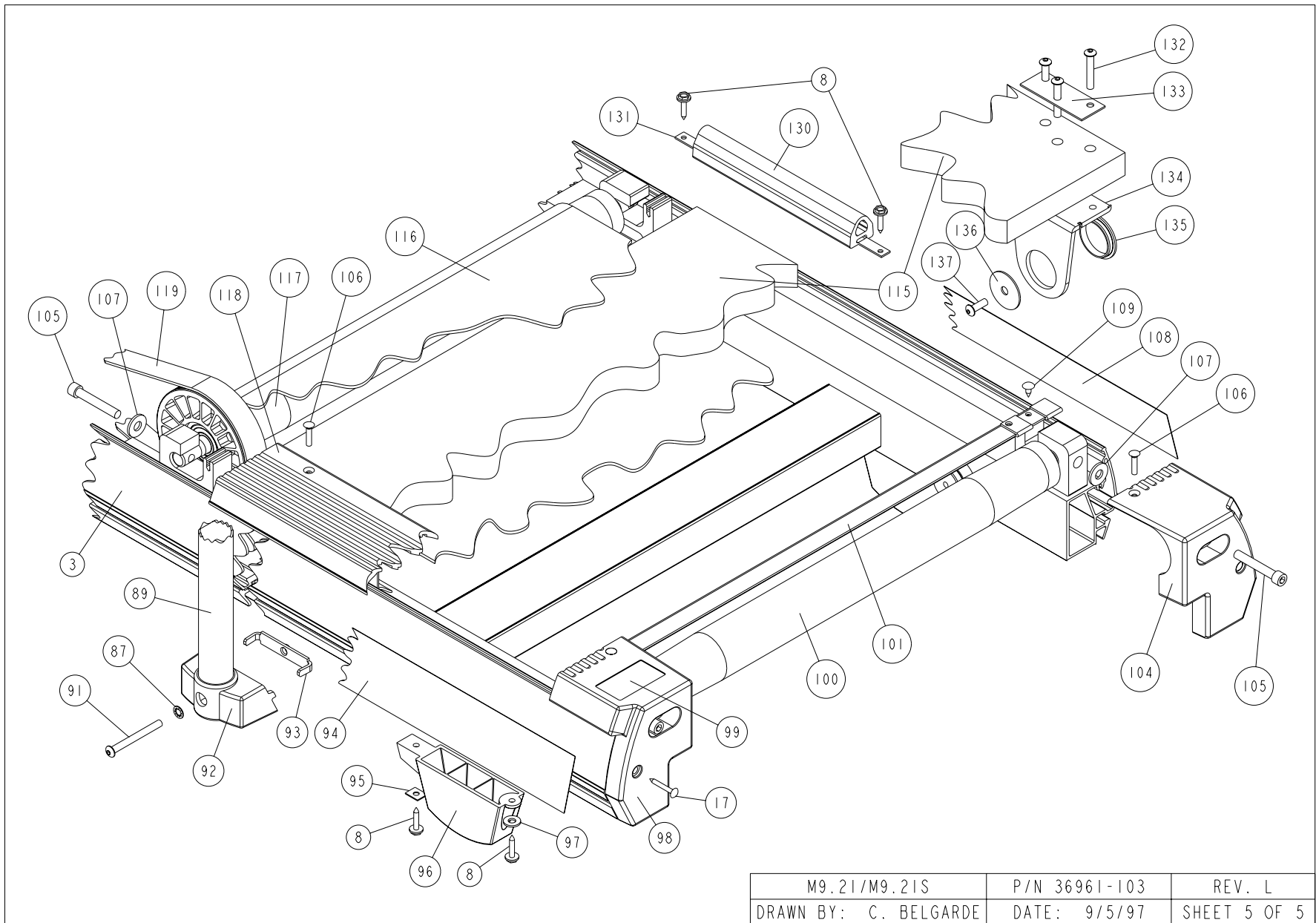

M9.21/M9.21S	P/N 36961-103	REV. L
DRAWN BY: C. BELGARDE	DATE: 9/5/97	SHEET 5 OF 5

**9.21 (serial code F5)**

<b>Part Number</b>	<b>Description</b>	<b>Bubble Number</b>
PGKN016-050	SCREW,S/T,#8X1/2,TRS,PHIL,BLK	1
50974-106	ASSY,HOOD WITH LABELS,SFT	2
36927-101	LABEL, SIDE RAIL, RT FR, M9.21	4
36882-101	BRACKET, LOWER PCA	5
10332-101	MOUNT, CABLE TIE	6
10123-102	CABLE TIE, 3-7/8 LONG,WHITE,NYL	7
PHCN019-075	SCREW,S/T,#10X3/4,WSHRHXHD,ZN,	8
PKCN019-075	SCREW,S/T,#10X.75,WSHHXHD,ZN	8
WALCN038-009	WASHER, 3/8 SPLIT LOCK, ZINC	9
10136-101	CLIP, U TYPE, TINNERMAN, #8	11
WACN019-005	WASHER, FLT, #10X.500X.049,ZN	12
36874-501	PLATE, DRESS, PAINTED	14
49321-101	ASSY, LINE CORD, 120V, 15A , 122" L	15
MGKN013-025	SCREW,MCH,6-32X1/4,PANHD,PHIL,	16
PGKN016-125	SCREW,S/T,#8X1-1/4,TRS,PHIL,	17
10237-101	LOCKNUT, 7/8 ,NYLON,BLACK	18
10435-101	CKT BRKR,250V,MAGNETIC,ROCKER,	19
36927-102	LABEL, SIDE RAIL, LT FR, M9.21	21
36937-104	WELDMENT, COLUMN, PAINTED	22
36937-106	WELDMENT, COLUMN, PAINTED	22.01
CAKN038-250	SCREW,SKHD,3/8-16X2.50,BLK ZN,LK	23
37437-102	LABEL, FUSE, FIRE HAZARD	26
37180-102	ASSY, LWR ELECT. MODULE	27
MAACN019-075	SCREW,MCH,10-32X3/4,HEX,ZN	28
36871-101	BRACKET, BASE PIVOT	30
36872-101	BRACKET, MOTOR PIVOT	31
HACN038-600	SCREW,3/8-16X6,HEX,GR 2,ZN	32
HDCN031-063	SCREW,HEX,GR 5,5/16-24X5/8,ZN	33
WATNN033-003	WASHER, LK-INT, 5/16, ID=.325,	34
31551-103	INDUCTOR, 6.7MH, 3A, W/LEADS,	36
MGCN016-038	SCREW,MCH,8-32X3/8,PANHD,PHIL,	37
10036-101	CLAMP,CAPACITOR,2.0 NOM	38
MGCN016-063	SCREW,MCH,8-32X5/8,PANHD,PHIL,	40
KGCN016-013	LOCKNUT, STARWASHER 8-32, HEX	41
33272-101	LABEL, CAPACITOR DISCHARGE	42
31815-105	ASSY, CABLE, CAPICATOR TO MTR,	43
MHCN019-025	SCREW,MCH,10-32X1/4,PANHD,PHIL	44
36862-105	MOTOR, LIFT ACTUATOR	45
10479-101	CAPACITOR CAP,2 OD X 1 HIGH	46
WCCN038-008	WASHER, FLT, 3/8X1.00X.083	47
10400-103	PIN, HITCH, .093 DIA, SILVER CAD, #	48
10753-101	FAN,MOTOR HUB	49
36892-101	MOTOR,1.7 HP, 3200 RPM, 90VDC,	50
10401-104	PIN, CLEVIS, 3/8 X 2.00,SILVER	52
EMKN008-010	SCREW,SET,M8-1.25XM10,KNRLDCUP	54
32947-102	LABEL, FLYWHEEL TARGET	55
KGCN011-009	LOCKNUT, STARWASHER, 4-40	57
36833-102	ASSY,REMOTE SENSOR,TWISTED	58
MGCN011-063	SCREW,MCH,4-40X5/8,PANHD,PHIL,	59
BNCN031-350	J-BOLT, HOOK, 5/16-18X3.5,ZN	60

31894-102	ASSY, CABLE, CAPACITOR TO MTR,	61
HCKN050-250	SCREW,HEX,GR 5,1/2-13X2-1/2,BLK ZN	64
WBCN050-010	WASHER, FLT, 1/2, ID=.531,	65
36192-101	BUSHING, SPANNER	66
44270-101	WHEEL, LIFT	67
KACN050-019	LOCKNUT,HALF,1/2-13,ZN	68
36879-104	PIN, LIFT	69
36920-801	SHAFT, LIFT PLATFORM	70
PMKN016-050	SCREW,TCS,#8X1/2,PHIL,BLK ZN,TYPE25	71
37812-101	ASSY, INTERCONNECT CABLE	72
37742-101	PCA, SAFETY SWITCH	73
50971-109	ASSY, DISPLAY HOUSING W/O	83
37990-101	PCA, DISPLAY	84
43547-101	ASSY,PCA&SW,921	84.01
37400-108	PROM,9.21,V1.08	85
36936-102	CLAMP, UPPER HANDRAIL, PAINTED	86
WATNN025-003	WASHER, LK-INT, ID=.25,	87
TAKN025-063	SCREW,BTHD,1/4-20X5/8,BLK ZN	88
TAKN025-250	SCREW,BTHD,1/4-20X2-1/2,BLK ZN	91
36102-103	PLATE, NUT	93
36932-102	LABEL, SIDE RAIL, LT RR,M9.21,	94
WBBNN022-004	WASHER, RECTANGULAR	95
36441-101	FOOT, REAR	96
WBNN025-007	WASHER, FLT, 1/4, ID= .281,	97
36122-501	LABEL, CAUTION, GREY	99
36914-102	ASSY,ROLLER,TAKE-UP,9.2X	100
36905-501	GUARD, ROLLER, REAR, PAINTED	101
CAKN031-200	SCREW,SKHD,5/16-18X2,BLK ZN,LK	105
PPKN019-075	SCREW,S/T,#10X3/4,FLATHD,PHIL,	106
WCCN025-007	WASHER, FLT, 1/4X.734X.065	107
36932-101	LABEL, SIDE RAIL, RT RR,M9.21,	108
PGCN019-050	SCREW,S/T,#10X1/2,TRS,PHIL,ZN,	109
37036-101	WASHER, BED SPRING	110
36118-103	STUD, BED, HEX DRIVE	111
33563-103	SPRING, BED SUPPORT	112
37033-101	BUSHING, SOFT DECK	113
50985-101	ASSY,BED,SFT	115
36355-101	RUNNING BELT,SIEGLING,17 X 110	116
36913-103	ASSY, DRIVE ROLLER	117
10217-106	BELT, DRIVE, 240J10, POLY V	119
KHCN019-013	LOCKNUT, STARWASHER, 10-32,	120
KDCN031-025	LOCKNUT, FULL 5/16-18, ZINC	121
CAKN038-275	SCREW,SKHD,3/8-16X2.75,BLK ZN,LK	122
DCKN019-100	SCREW,WOOD #10X1, L=1.00	123
37621-101	LABEL,GROUND EFFECTS,OVAL,DURO-LENZ	124
37175-101	ASSY, GROUND STRAP,5	126
KGCN031-027	LOCKNUT,STARWASHER,5/16-18,1/2	127
37705-101	SUPPORT, BED 12.0	130
TAKE025-150	SCREW,BTHD,1/4-20X1-1/2,BLK ZN	132
WNNN026-006	WASHER, FLT, 1/4X.625X.063,STL	133
37650-202	BRACKET, HINGE, PAINTED	134
37656-102	BEARING, FLANGE	135

TFKN025-075	SCREW,BTHD,1/4-20X3/4,BLK ZN	137
37658-202	PLATE, WASHER	138
10123-101	CABLE TIE,11 LONG,WHITE,NYL	201
36141-101	SHIPPER,BOTTOM,9.10,9.20,9.20S	202
36142-101	SHIPPER, TOP, 9.10,9.20,9.20S	203
36678-107	SHIPPER, FOAM BLOCK, LEFT	207
36678-108	SHIPPER, FOAM BLOCK, RIGHT	208
36907-103	SHIPPER, HANDRAIL SUPPORT,	210
36911-104	SHIPPER, LIFT MECH, 921I,921SI	211
37123-102	SHIPPER, SUPPORT,TARGA/DISPLAY	216
50979-104	ASSY, SHIPPER, 9.21	217
33881-101	SHIPPER, FOAM, 180 EA/ROLL	223
11408-101	NUT,LIFT,DELRIN,8THRDS/INCH	227
10427-111	FUSE,SLOW,.25A,250V,1/4 DIA	250
10427-140	FUSE,SLOW,2A,250V,1/4 DIA	250
10427-111	FUSE,SLOW,.25A,250V,1/4 DIA	251
10427-140	FUSE,SLOW,2A,250V,1/4 DIA	251
20002-108	BRUSH, MOTOR (YP00516)	990
20002-101	BRUSH, MOTOR (YP00507)	991